

Performance Sail Kit Assembly Instructions Walker Bay 8



Walker Bay
boats

IMPORTANT SAFETY INFORMATION

- READ OWNERS MANUAL. IMPROPER USE MAY CAUSE INJURY OR DEATH.
- EACH PASSENGER MUST HAVE AN APPROVED PERSONAL FLOTATION DEVICE.
- CARRY AN OAR AND BAILER ON BOARD WHILE SAILING.
- USE A BUDDY SYSTEM, SAIL WHERE PEOPLE CAN SEE AND HELP YOU IF NECESSARY.
- DO NOT USE A MOTOR OR SAIL UNLESS YOU USE THE EQUIPMENT IN THE MANNER INTENDED AND/OR AS DESCRIBED IN THE MANUAL.
- DO NOT USE THIS BOAT UNDER THE INFLUENCE OF DRUGS OR ALCOHOL.
- DO NOT USE THIS BOAT IF YOU SUSPECT A CRACK OR A HOLE. IT MAY BE UNSAFE.
- USE CAUTION WHEN ENTERING OR EXITING THE BOAT.
- KEEP YOUR WEIGHT CENTERED AND DISTRIBUTE THE WEIGHT OF GEAR AND PASSENGERS EVENLY.
- DO NOT USE THIS BOAT AS A TOW CRAFT.
- THIS BOAT IS NOT A TOY. ADULT SUPERVISION ADVISED.
- PARTS AND SPECIFICATIONS SUBJECT TO CHANGE WITHOUT NOTICE.
- FOR SAFETY INFORMATION OR PARTS, CALL WALKER BAY BOATS AT:
(888) 44-WALKER OR (604) 682-5699.

GB

F

E

D

I

NL

S

Checklist of Components
Liste de contrôle des composants
Lista de comprobación de los componentes
Bauteil-Checkliste
Lista del componenti
Stuklijst

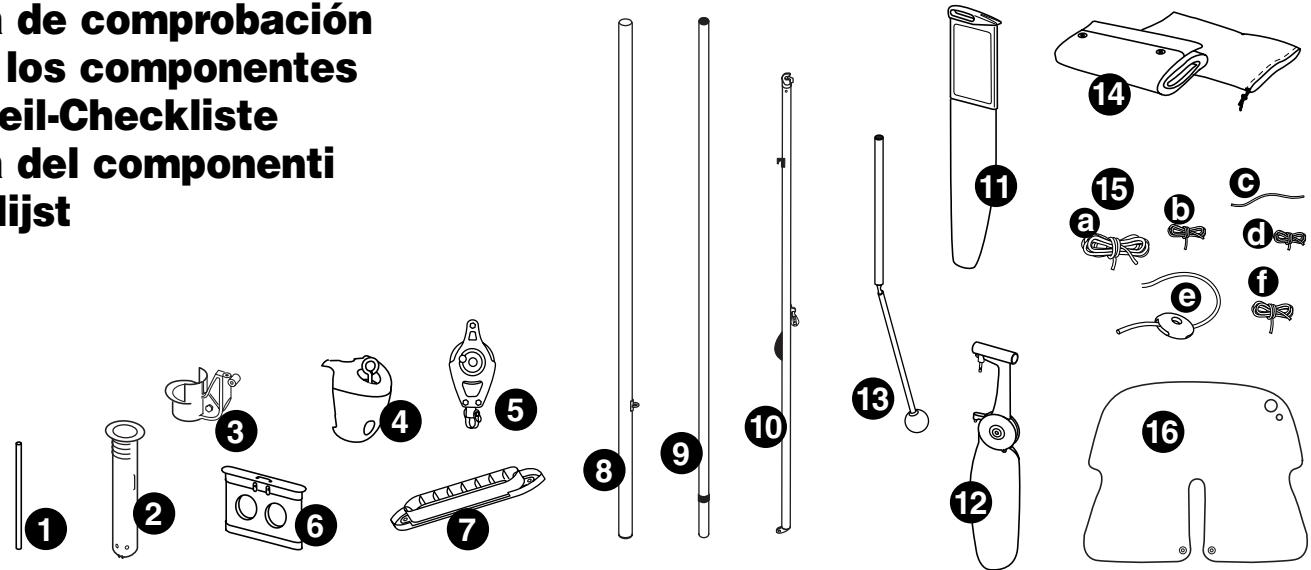

SRWB8001

GB

Checklist of Components (Specifications and contents subject to change without notice)

1. Wooden Dowel 1 ea.	15. Line Kit
2. Mast Support Tube 1 ea.	a. Mainsheet Line
3. Mast Support Clamp 1 ea.	160 in. (4.07 m) Green 1 ea.
4. Seat Block Clamp 1 ea.	b. Outhaul Line
5. Ratchet Block 1 ea.	50 in. (1.27 m) Yellow 1 ea.
6. Seat Plug 1 ea.	c. Clew Line
7. Open Keel Plate Cover 1 ea.	12 in. (0.30 m) Yellow 1 ea.
8. Lower Mast Half (with gooseneck ring) 1 ea.	d. Cunningham Line
9. Upper Mast Half 1 ea.	32 in. (0.81 m) Red 1 ea.
10. Boom 1 ea.	e. Vang Line
11. Daggerboard 1 ea.	60 in. (1.53 m) Blue 1 ea.
12. Rudder (Three Position Kick-Up Style) 1 ea.	f. Shock Cord (Bungee Cord)
13. Tiller Handle 1 ea.	78 in. (1.98 m) Green 1 ea.
14. Performance Sail 1 ea.	16. Flotation Bag 1 ea.

F

Liste de contrôle des composants (spécifications et contenus sujets à modifications sans préavis)

1. Cheville en bois 1	15. Kit de cordages
2. Tube de support du mât 1	a. Ecoute de grand voile
3. Collier de support du mât 1	Cordage vert de 4,07 m 1
4. Collier du siege 1	b. Hale-dehors
5. Bloc d'encliquetage 1	Cordage jaune de 1,27 m 1
6. Bouchon pour siège 1	c. Point d'écoute
7. Couverture de quille ouverte 1	Cordage jaune de 0,30 m
8. Moitié inférieure du mât (avec bague à col de cygne) 1	d. Cunningham
9. Moitié supérieure du mât 1	Cordage rouge de 0,81 m 1
10. Bôme 1	e. Hale-bas
11. Dérive 1	Cordage bleu de 1,53 mètres 1
12. Gouvernail (type relevable à trois positions) 1	f. Corde élastique
13. Poignée de barre 1	Cordage vert de 1,98 m 1
14. Voile 1	16. Sac d matériel 1

E

Lista de comprobación de los componentes (Las especificaciones y el contenido podrán alterarse sin previo aviso)

1. Clavija de madera 1	15. Cordaje
2. Tubo de soporte del mástil 1	a. Línea de escota mayor
3. Mordaza de soporte del mástil 1	160" (4,07 m) – Línea verde 1
4. Mordaza del asiento 1	b. Línea de driza de fuera
5. Bloque de trinquete 1	50" (1,27 m) – Línea amarilla 1
6. Tapa del asiento 1	c. Línea de puño
7. Tapa de placa de quilla abierta 1	12" (0,30 m) – Línea amarilla 1
8. Mitad inferior del mástil (con anilla en 'S') 1	d. Línea Cunningham
9. Mitad superior del mástil 1	32" (0,81 m) – Línea roja 1
10. Botavara 1	e. Línea de osta
11. Orza alzable 1	60" (1,53 m) – Línea azul 1
12. Timón (tres posiciones, tipo replegable) 1	f. Cuerda antisacudidas (cuerda bungee)
13. Caña del timón 1	78" (1,98 m) – Cuerda verde 1
14. Vela de altas prestaciones 1	16. Bolsa de aparejo

D**Bauteil-Checkliste** (Spezifikationsänderungen bleiben vorbehalten)

- | | | | |
|---|------|--|------|
| 1. Holzdübel | je 1 | 15. Seilsatz | |
| 2. Mastaufnahmerohr | je 1 | a. Großschottau mit Traveller-Beschlag | |
| 3. Mastklammer | je 1 | 160 Zoll (4,07 m) grün | je 1 |
| 4. Sitzklemme | je 1 | b. Ausholleine | |
| 5. Ratschenblock | je 1 | 50 Zoll (1,27 m) gelb | je 1 |
| 6. Sitzverschluss | je 1 | c. Schothornleine | |
| 7. Kieldeckplatte | je 1 | 12 Zoll (0,30 m) gelb | je 1 |
| 8. Mastunterteil (mit Segelhalsbeschlag) | je 1 | d. Cunningham-Leine | |
| 9. Mastoberteil | je 1 | 32 Zoll (0,81 m) rot | je 1 |
| 10. Baum | je 1 | e. Vang-Leine | |
| 11. Schwert | je 1 | 60 Zoll (1,53 m) blau | je 1 |
| 12. Ruder (drei Positionen, hochklappbar) | je 1 | f. Dämpfungsschnur (Bungee-Schnur) | |
| 13. Pinnenausleger | je 1 | 78 Zoll (1,98 m) grün | je 1 |
| 14. Leistungssegel | je 1 | 16. Zeugtasche | je 1 |

I**Lista del componenti** (Specifiche e dati soggetti a variazione senza preavviso)

- | | | | |
|---|---|---|---|
| 1. Caviglia di legno | 1 | 15. Corredo di cime | |
| 2. Supporto albero | 1 | a. Scotta con anello per cima di scorrimento | |
| 3. Collare supporto albero | 1 | 160 poll. (4,07 m) colore verde | 1 |
| 4. Stopper per la cima | 1 | b. Alafuori | |
| 5. Blocchetto di arresto | 1 | 50 poll. (1,27 m) colore giallo | 1 |
| 6. Chiusura scassa di deriva | 1 | c. Cima d'angolo | |
| 7. Protezione lamiera di chiglia | 1 | 12 poll. (0,30 m) colore giallo | 1 |
| 8. Parte inferiore dell'albero (con anello di articolazione del boma) | 1 | d. Cima Cunningham | |
| 9. Parte superiore dell'albero | 1 | 32 poll. (0,81 m) colore rosso | 1 |
| 10. Boma | 1 | e. Ostino | |
| 11. Deriva | 1 | 60 poll. (1,53 m) colore azzurro | 1 |
| 12. Timone (tipo a tre posizioni) | 1 | f. Fune antidanneggiamento deriva (fune Bungee) | |
| 13. Barra del timone | 1 | 78 poll. (1,98 m) colore verde | 1 |
| 14. Vela | 1 | 16. Sacco per manovre | 1 |

NL**Stuklijst** (Specificaties en inhoudsopgave vatbaar voor wijzigingen zonder voorafgaande kennisgeving)

- | | | | |
|--|-------|------------------------------------|-------|
| 1. Houten nagel | 1 st. | 15. Tuigage | |
| 2. Maststeunbuis | 1 st. | a. Grootshootlijn met overloopring | |
| 3. Maststeunklem | 1 st. | 4,07 m groen lijn | 1 st. |
| 4. Bankjeklamp | 1 st. | b. Schoothoornlijn | |
| 5. Ratelblok | 1 st. | 1,27 m gele lijn | 1 st. |
| 6. Afdichtprop | 1 st. | c. Geitouw | |
| 7. Afdekking van open kielplaat | 1 st. | 0,30 m wit/gele lijn | 1 st. |
| 8. Onderste masthelft (met halsdoekring) | 1 st. | d. Cunningham-lijn | |
| 9. Bovenste masthelft | 1 st. | 0,81 m rood/witte lijn | 1 st. |
| 10. Giek | 1 st. | e. Pardoelijjn | |
| 11. Zwaard | 1 st. | 1,53 m wit/blauwe lijn | 1 st. |
| 12. Roer (met drie standen, van het op klaptype) | 1 st. | f. Amortiseurkoord | |
| 13. Helmstok | 1 st. | 1,98 m wit/groen koord | 1 st. |
| 14. Performance-zeil | 1 st. | 16. Tas met tuig | 1 st. |

S**Standardutrustning** (Specifikationer och innehåll kan ändras utan varsel)

- | | | | |
|---|---|------------------|---|
| 1. Plastlås | 1 | 15. Komplettsats | |
| 2. Mastfot | 1 | a. Uthalslina | |
| 3. Mastfotsfäste | 1 | 1,57m oml | 1 |
| 4. Blockfäste för toften | | | |
| 5. Spärrblock | | | |
| 6. Övre delen av masten | | | |
| 7. Nedre delen av masten m. : | | | |
| 8. Bom | | | |
| 9. Rorkult | | | |
| 10. Uppfällbart roder | | | |
| 11. Centerbord | 1 | f. | 1 |
| 12. W810 högprestandasegel (m. latta) | 1 | 16. | 1 |
| 13. Extra flytkudde | 1 | | |
| 14. Kickslagskryssbult | 1 | | |

**SWEDISH TEXT TO
COME**

Preparation

Follow Steps A through J

Préparation

Suivre les étapes de A à J

Preparativos

Siga los pasos A a J

Vorbereitung

Schritte A bis J ausführen

Preparazione

Eseguire nell'ordine le operazioni da A a J

Voorbereidingen

Volg stap A t/m J

Seglingsförberedelse

Följ steg A till J

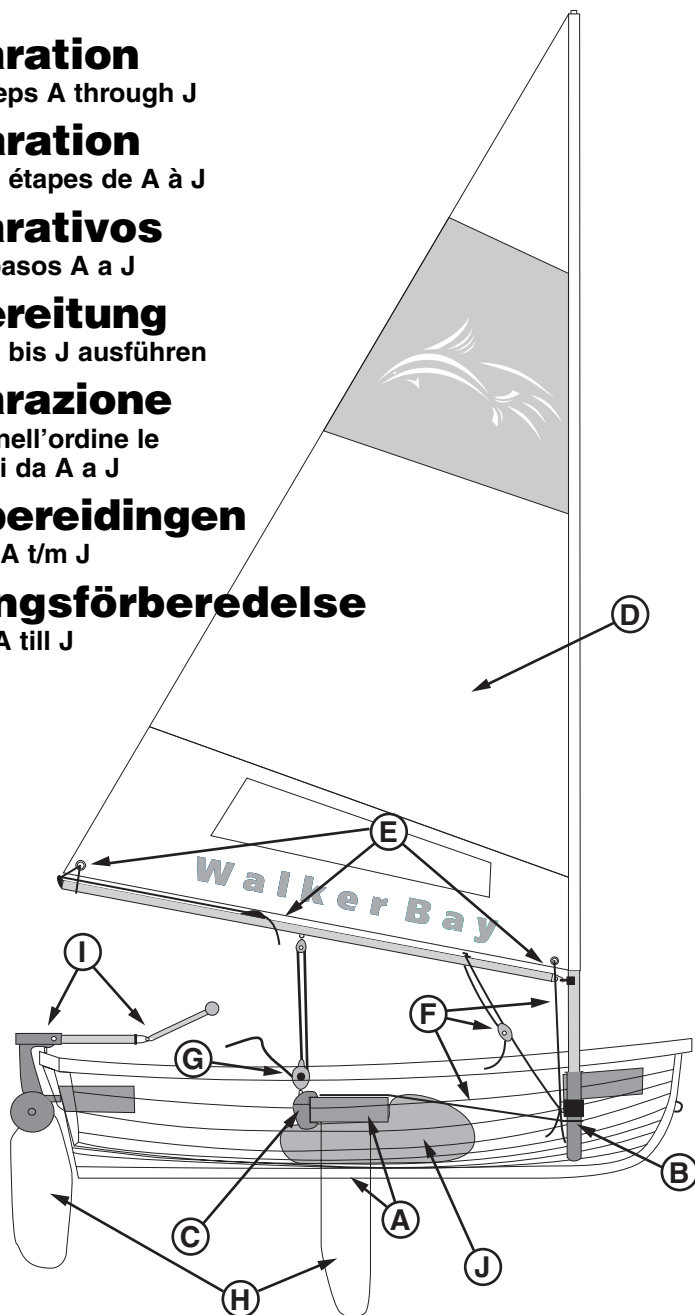

- Step A. Opening Daggerboard Well
- Step B. Installing Mast Support Tube
- Step C. Attaching the Seat Block Clamp and Ratchet Block
- Step D. Raising the Sail
- Step E. Attaching the Sail to the Boom
- Step F. Securing the Vang Line, Cunningham Line and Shock Cord
- Step G. Securing the Mainsheet Line to the Ratchet Block
- Step H. Inserting the Daggerboard and Rudder
- Step I. Installing and Operating the Rudder
- Step J. Installing the Flotation Bag

GB

- Etape A. Ouverture du puits de dérive
- Etape B. Installation du tube de support du mât
- Etape C. Installation du collier de siège et du bloc d'encliquetage
- Etape D. Hissage de la voile
- Etape E. Fixation de la voile à la bôme
- Etape F. Fixation du hale-bas, cunningham et la corde élastique
- Etape G. Fixation de l'écoute de grand voile au bloc d'encliquetage
- Etape H. Mise en place de la dérive et du gouvernail
- Etape I. Fixation et fonctionnement du gouvernail
- Etape J. Gonflage du sac de flottaison

F

- Paso A. Apertura de la cavidad para la orza alzable
- Paso B. Instalación del tubo de soporte del mástil
- Paso C. Instalación de la mordaza del asiento y bloque de trinquete
- Paso D. Izada de la vela
- Paso E. Sujeción de la vela a la botavara
- Paso F. Sujeción de la línea de osta, la línea Cunningham y la cuerda antisacudidas
- Paso G. Sujeción de la línea de escota mayor al bloque de trinquete
- Paso H. Inserción de la orza alzable y del timón
- Paso I. Instalación y operación del timón
- Paso J. Inflado de la Bolsa de Flotación

E

- Schritt A. Öffnen des Schwertgehäuses
- Schritt B. Montage des Mastaufnahmerohrs
- Schritt C. Befestigen der Sitzklemme und des Ratschenblocks
- Schritt D. Aufziehen des Segels
- Schritt E. Befestigen des Segels am Baum
- Schritt F. Befestigen der Vang-Leine, der Cunningham-Leine und Dämpfungsschnur
- Schritt G. Befestigen des Großschottaus am Ratschenblock
- Schritt H. Einschieben des Schwertes und des Ruders
- Schritt I. Montage und Betätigung des Ruders
- Schritt J. Installation des Schwimmsackes

- Fase A. Apertura della scassa di deriva
- Fase B. Montaggio supporto albero
- Fase C. Fissaggio dello stopper per la cima e del blocchetto di arresto
- Fase D. Innalzamento della vela
- Fase E. Attacco della vela al boma
- Fase F. Fissaggio dell'ostino, della cima Cunningham e fune antidanneggiamento
- Fase G. Fissaggio della cima di scorcimento scocca al blocchetto di arresto
- Fase H. Inserimento della deriva e del timone
- Fase I. Montaggio e funzionamento del timone
- Fase J. Gonfiaggio del cuscino di galleggiamento

- Stap A. Openen van de zwaardkast
- Stap B. Installeren van de maststeunbuis
- Stap C. Bevestigen van de bankje-klamp en het ratelblok
- Stap D. Hijzen van het zeil
- Stap E. Bevestigen van het zeil aan de giek
- Stap F. Vastzetten van de pardoelijn, de Cunningham-lijn en het amortiseurkoord
- Stap G. Vastzetten van de grootschootlijn aan het ratelblok
- Stap H. Insteken van het zwaard en het roer
- Stap I. Aanbrengen en bedienen van het roer
- Stap J. Opblazen van de drijfzak

- Steg A. Öppna centerbordstrumman och ta bort skyddsplattan i botten
- Steg B. Installera mastfoten
- Steg C. Befästa sätesklemmen och ratelblocket
- Steg D. Hisa seglet
- Steg E. Befästa seglet på giek
- Steg F. Fäst vangsremsan, Cunninghamsremsan och dämpningsremsan
- Steg G. Fäst grottschootsremsan till ratelblocket
- Steg H. Fäst lina för storskot på spärrblocket
- Steg I. Installera extra flytkudde vid behov

**SWEDISH
TEXT TO
COME**

D

I

NL

S

A

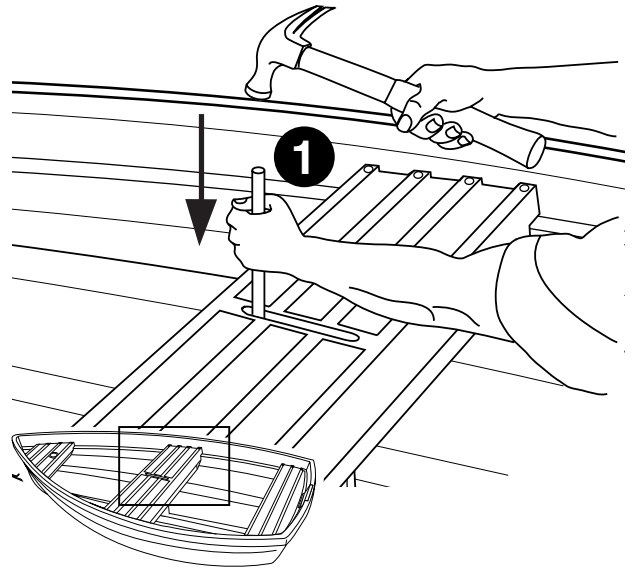
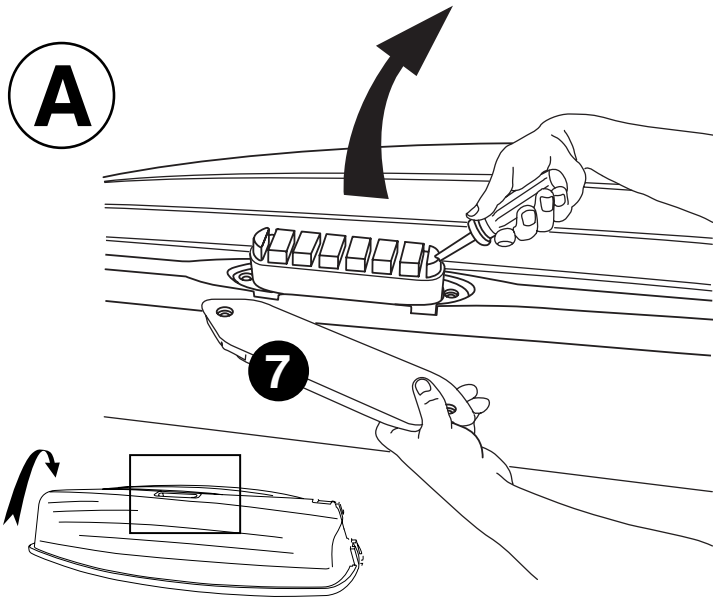

B

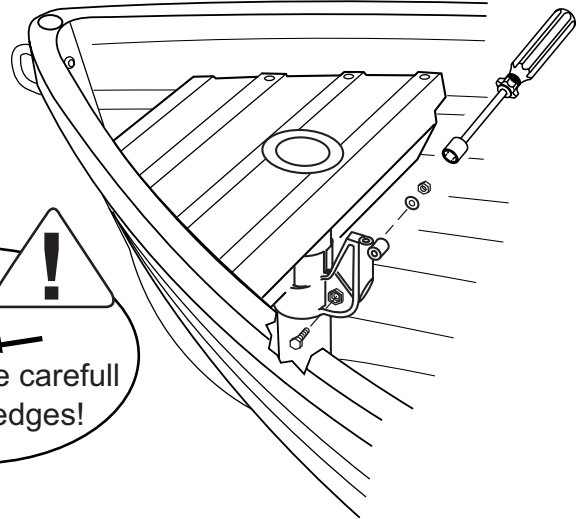
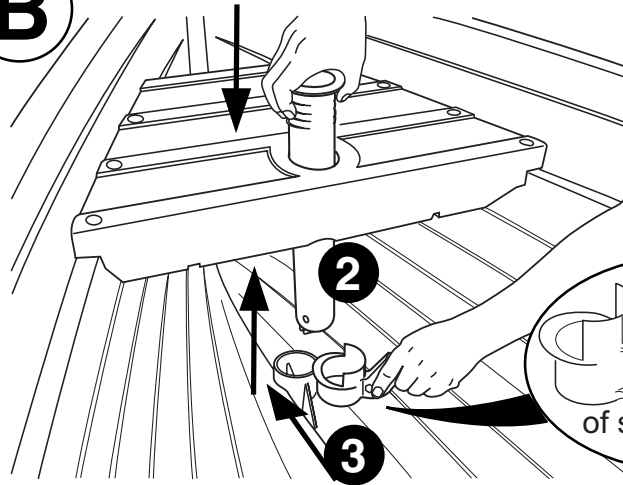

C

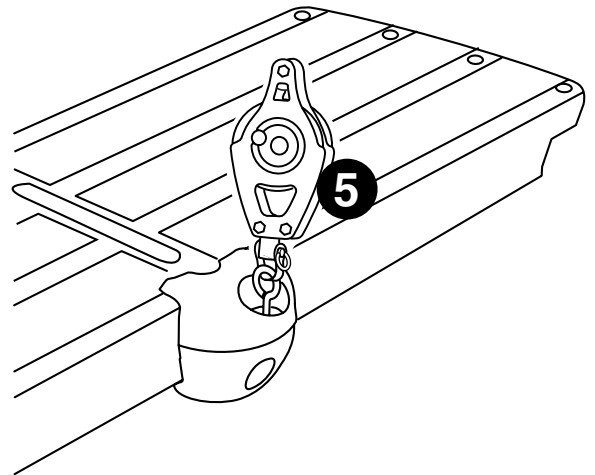
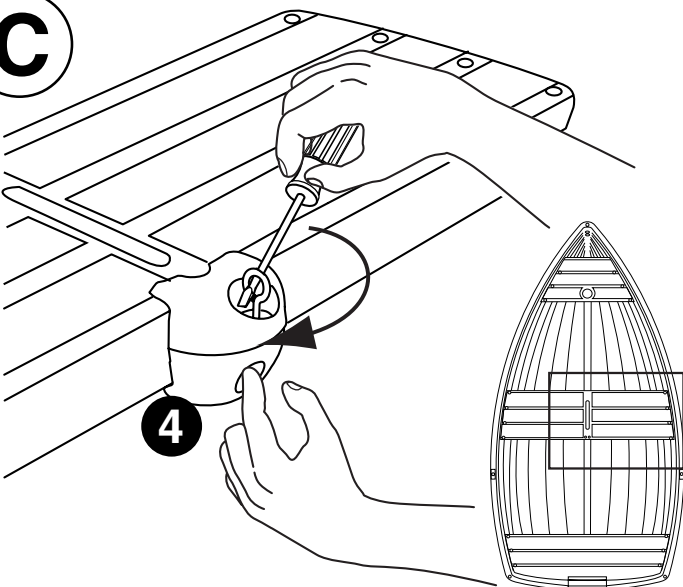

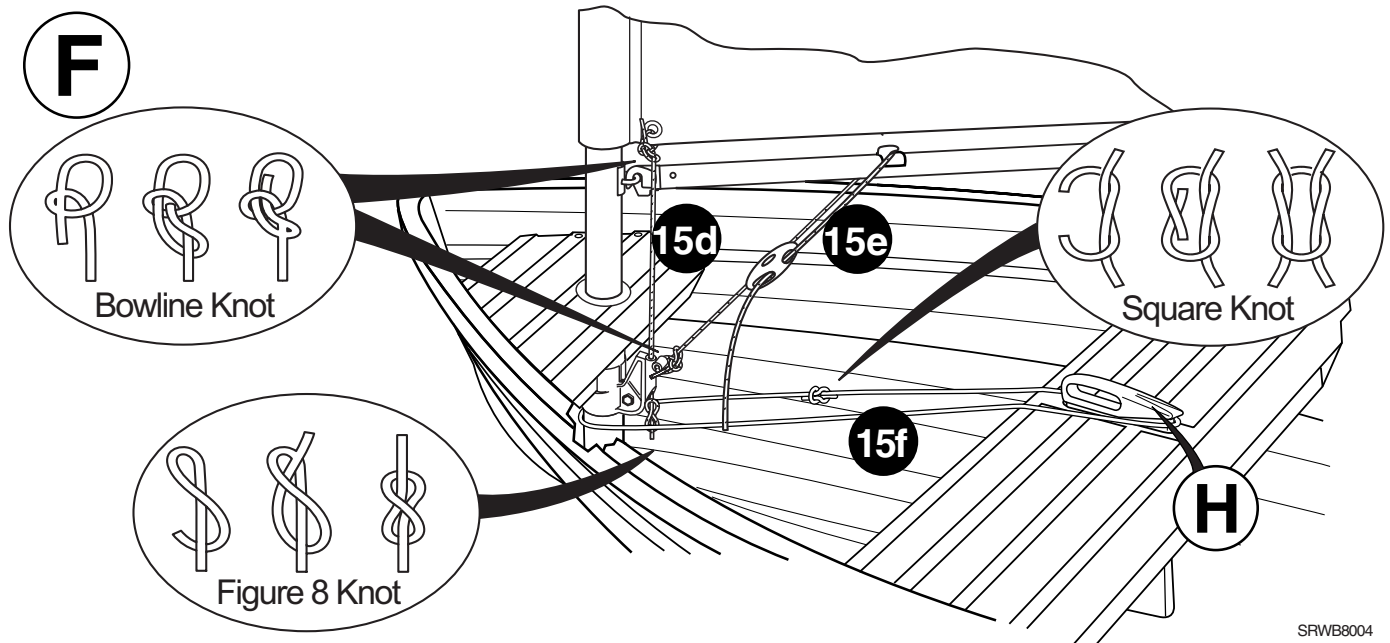
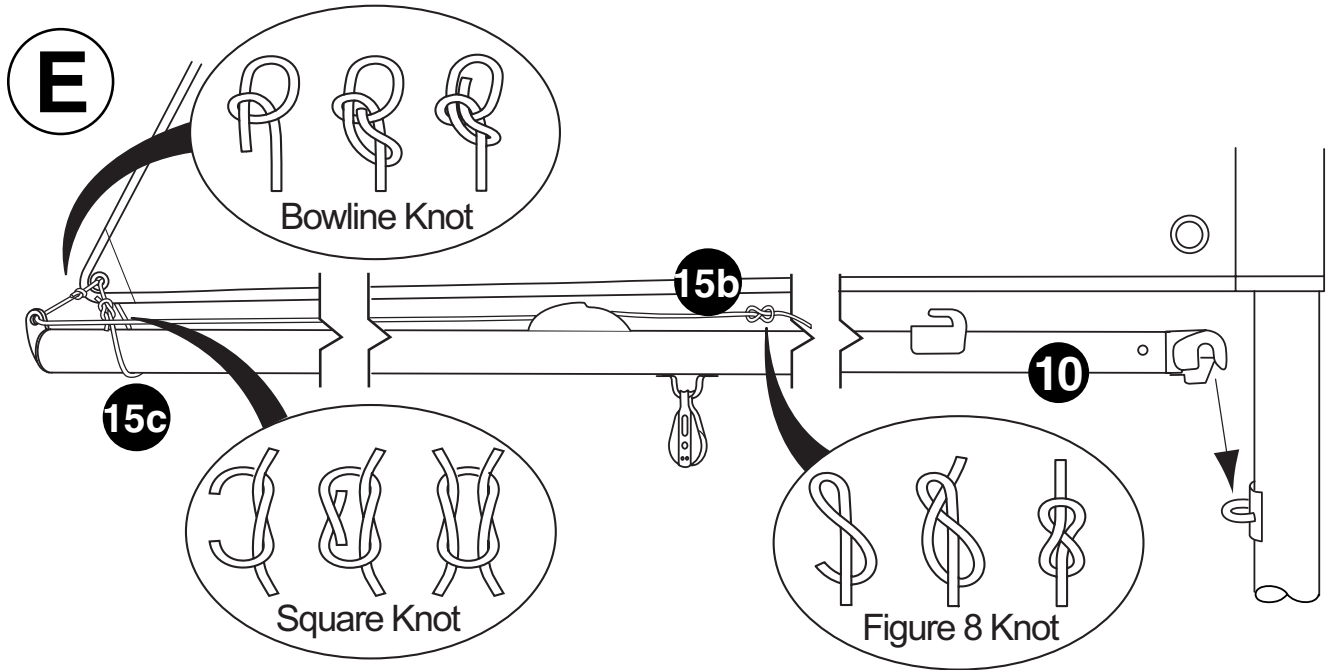
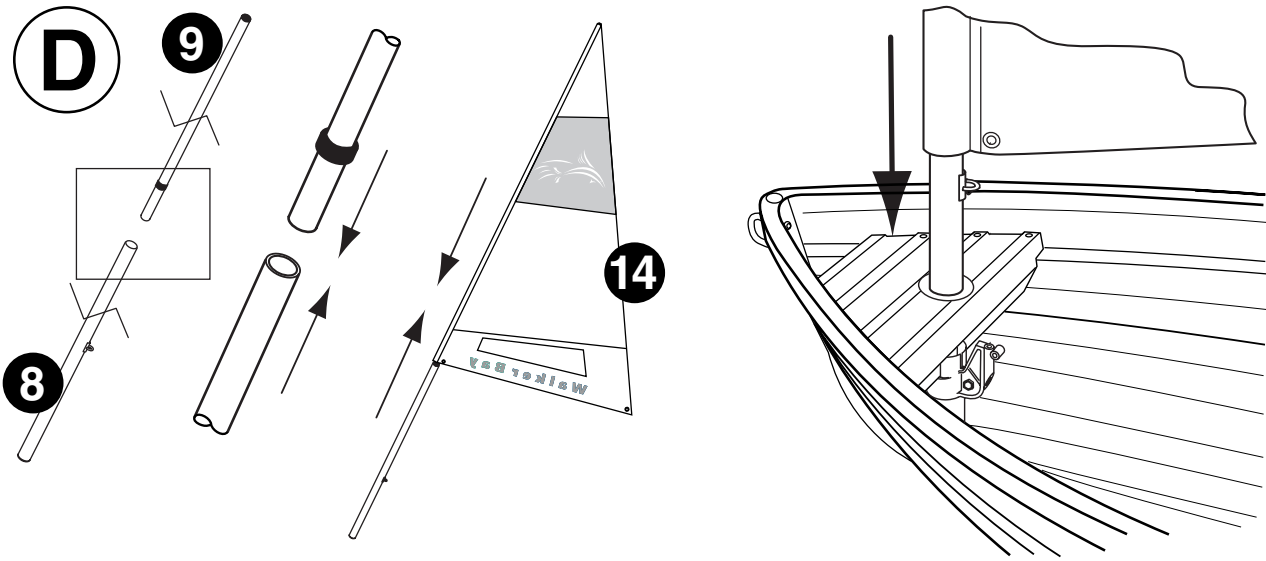

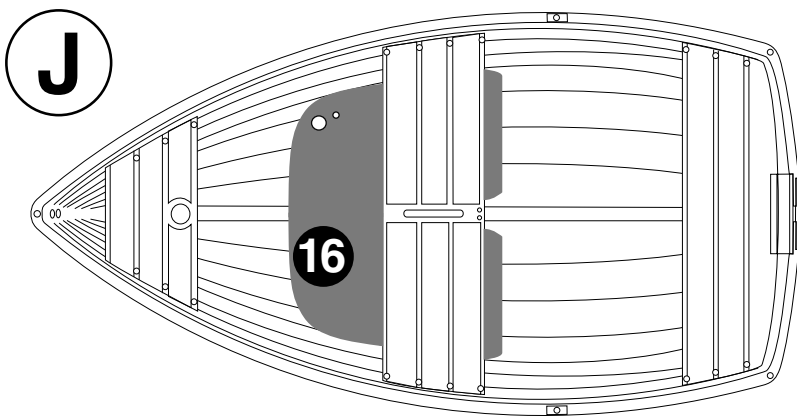
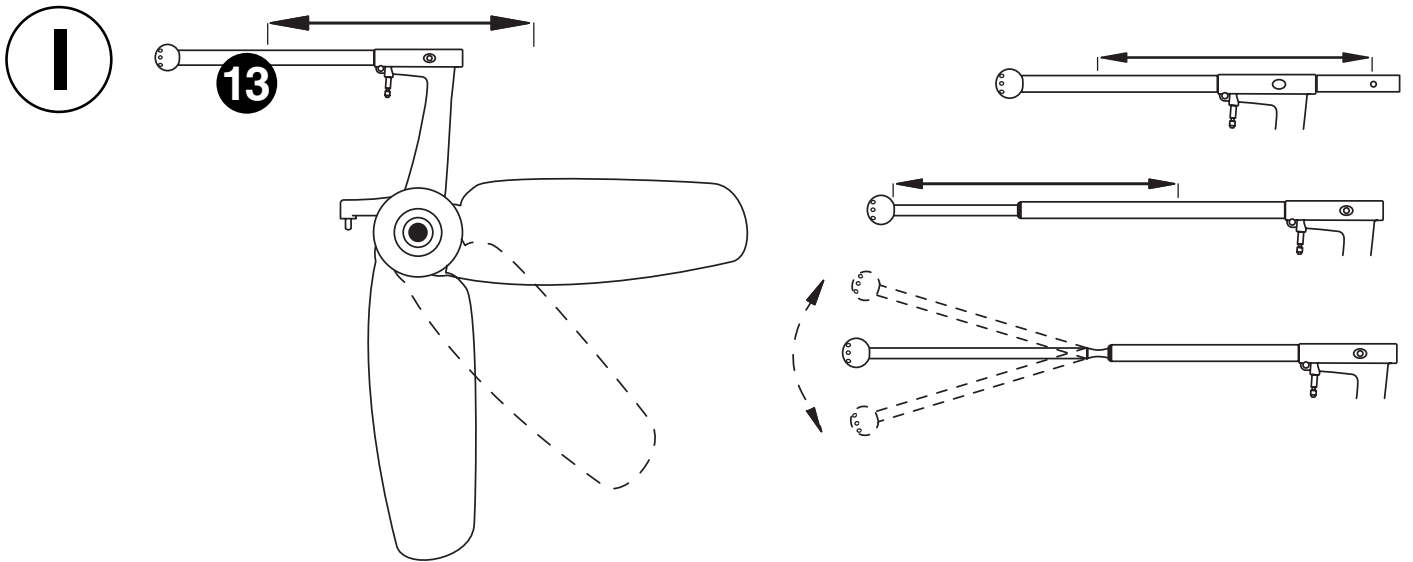
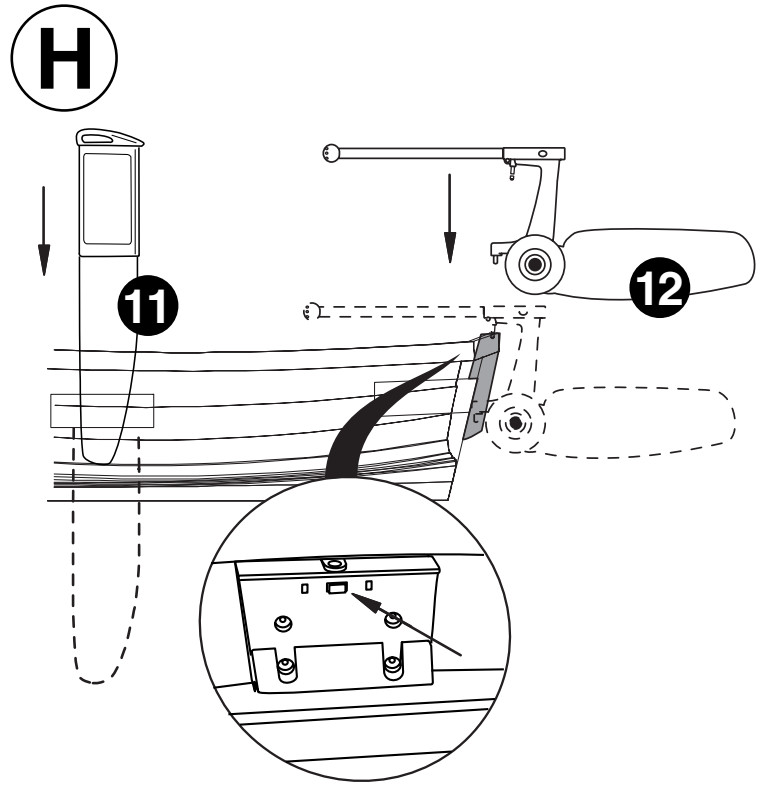
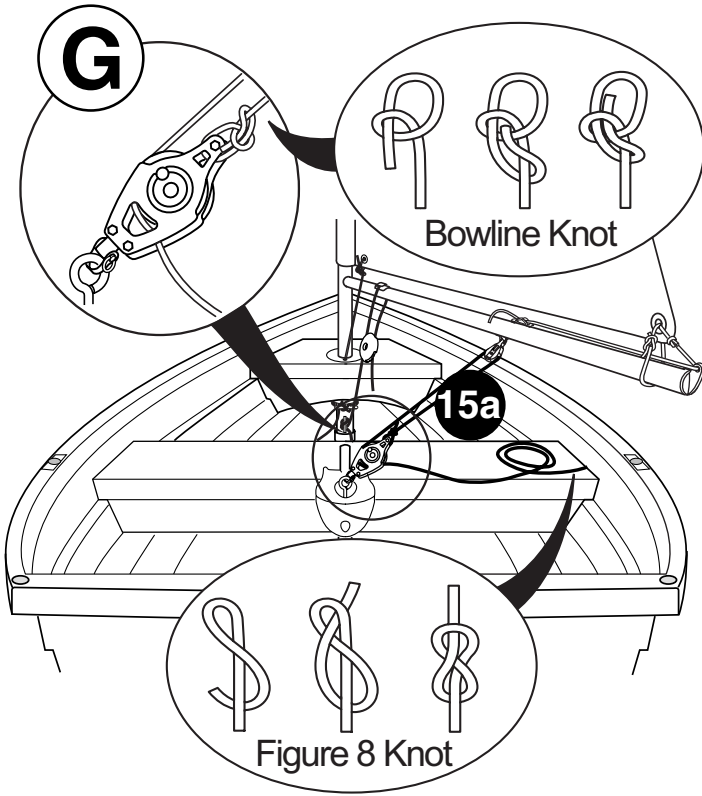

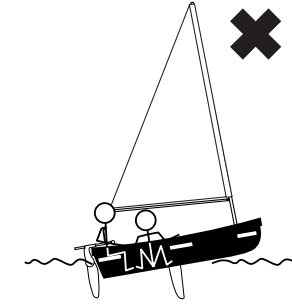
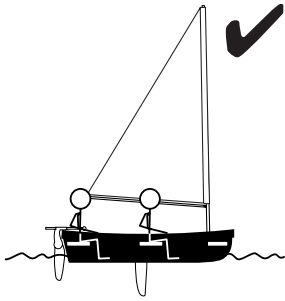
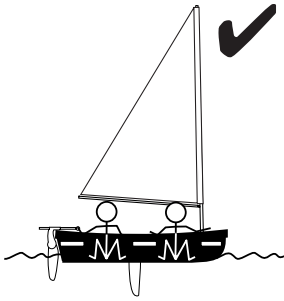
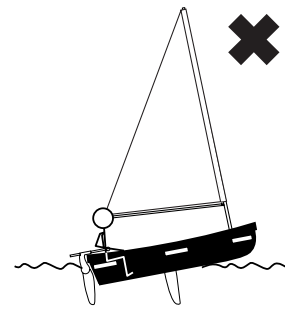
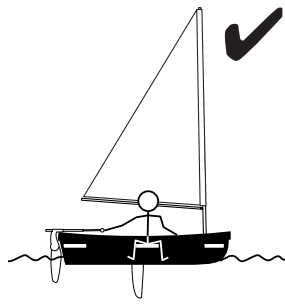
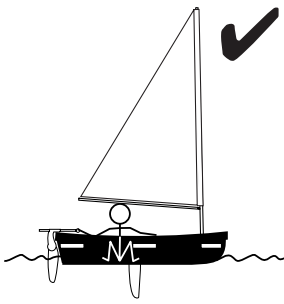

1

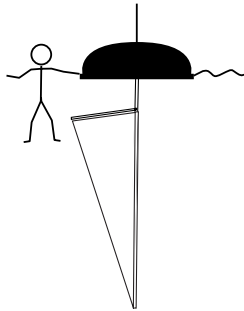

2

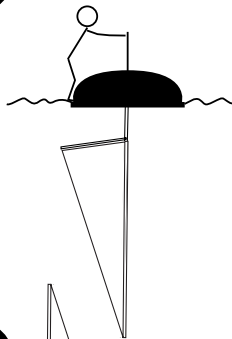

3

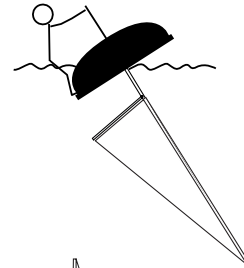

4

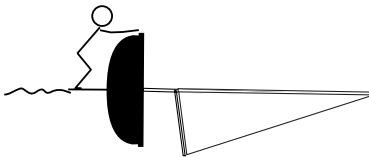

5

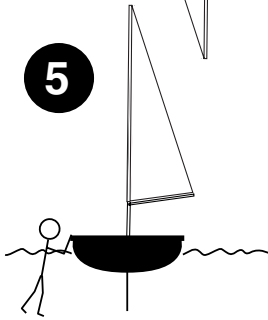

6



Walker Bay boats

Operations: 607 West Ahtanum Road, Union Gap, WA 98903, USA Tel: 888-44WALKER (449-2553) Fax: 888-228-7222
Admin: WBB Marine Management, 770-1066 West Hastings St., Vancouver, BC V6E 3X1 Tel: 604-682-5699 Fax: 604-683-1877

email: info@walkerbay.com web: www.walkerbay.com